

SF₆ service equipment

For filling, cleaning and recovery of SF₆ gas

Model GPU-S-2000 and GPU-S-3000

WIKA data sheet SP 63.16



For further approvals,
see page 3

Applications

Filling, cleaning, recovery, evacuation and venting of filled switchgear, linear accelerators and other SF₆ gas-filled equipment

Special features

- Oil-free compressor and vacuum compressor
- Filtering of particles, humidity and decomposition products
- Low maintenance effort
- Operation via 10" touchscreen
- SIL 2 certified safety control, sensors and load cell



SF₆ service equipment with 300-litre tank

Description

The right instrument for each application - The GPU platform

The gas-handling equipment of the GPU platform enable the complete process from initial filling to processing to be carried out safely and intuitively.

The platform is available in 4 versions.

- Model GPU-B-2000
SF₆ service equipment in fully automated basic version
- Model GPU-S-2000
SF₆ service equipment with additional SIL 2 safety control
- Model GPU-B-3000
SF₆ service equipment at the highest performance level
- Model GPU-S-3000
SF₆ service equipment with additional SIL 2 safety control and the highest performance level

Extra high safety - model series S

The models GPU-S-2000 and GPU-S-3000 are equipped with an additional SIL 2 safety control that is unique on the market. As a result, operating errors and the escape of SF₆ gas are technically impossible.

All models of the GPU platform are optionally available with a filter process that allows the SF₆ gas to be brought to a lower humidity value directly on-site. Optionally, the GPU can be equipped with a WIKA gas humidity sensor, model GDHT-20, which enables filtering to a target value.

The SF₆ service equipment is an efficient and reliable solution that exceeds the current IEC standards for handling SF₆ gas. Low downtimes through long service intervals of more than 2,500 hours make them an extremely durable product that is always ready for use.

Specifications

Basic information		
Models		
GPU-B-2000	SF ₆ service equipment in fully automated basic version	
GPU-S-2000	SF ₆ service equipment with additional SIL 2 safety control	
GPU-B-3000	SF ₆ service equipment at the highest performance level	
GPU-S-3000	SF ₆ service equipment with additional SIL 2 safety control and the highest performance level	
Digital display		
Type of display	10"-colour LCD touchscreen	
Connections		
GIS	1 valve DN 20	Pressure range 0 ... 10 bar abs.
Gas cylinder	2 valve DN 20	Pressure range 0 ... 50 bar abs.
Atmosphere	1 valve DN 20	Pressure range 0 ... 1.2 bar abs.
Safety systems		
Safety control	Based on SIL 2 components	
SF ₆ gas warning equipment	0 ... 2,000 ppm _v , based on infrared technology	
Operating voltage		
	<ul style="list-style-type: none"> ■ AC 400 V, 3-phase, 50/60 Hz ±10 % ■ AC 240 V, 3-phase, 50/60 Hz ±10 % ■ AC 208 V, 3-phase, 50/60 Hz ±10 % 	
Filter element		
	<ul style="list-style-type: none"> ■ Molecular sieve ■ Aluminium oxide ■ Particle filter 1 µm ■ Max. water absorption: 75 g [2,65 oz] 	
Integrated tank, storage capacity		
	<ul style="list-style-type: none"> ■ Without tank ■ 300 litres ■ 600 litres ■ Stowage for 6 gas cylinders ■ Stowage for 10 gas cylinders 	
Integrated gas cylinder scales		
	Without scales	
	Without scales with pull-out, fixed to the GPU	Measuring range: 0 ... 120 kg [264.56 lb] Accuracy: ±50 g [±1.76 oz]
	Mobile scales	Measuring range: 0 ... 136 kg [299,83 lb] Accuracy: ±68 g [±2,4 oz]
Function expansion		
	<ul style="list-style-type: none"> ■ Humidity sensor to measure the humidity content and filtering to a target humidity value ■ Additional process connection for the simultaneous evacuation and recovery or filling ■ Evaporators 	
Tyres		
	Solid rubber, Ø 200 mm [7.874 in], with rollover protection	
Ingress protection		
	IP42	
Weight		
Without tank	Approx. 800 kg [1.764 lb]	
Without tank and wheels	Approx. 800 kg [1.764 lb]	
With empty 300-litre tank	Approx. 1.250 kg [2.756 lb]	
With empty 600-litre tank	Approx. 1.300 kg [2.867 lb]	
With empty stowage for 6 gas cylinders	Approx. 1.050 kg [2.315 lb]	
With empty stowage for 10 gas cylinders	Approx. 1.175 kg [2.591 lb]	

Operating conditions	
Operating temperature	-10 ... +40 °C [14 ... 104 °F]
Storage temperature range	-20 ... +60 °C [-4 ... +140 °F]
Relative humidity, condensation	< 95 % r. h. (non-condensing)

Oil-free compressor (SF ₆ gas)	
Output pressure	Gas flow rate
50 bar abs.	■ 6 m ³ /h at 50 Hz
	■ 7.3 m ³ /h at 60 Hz
	■ 10.2 m ³ /h at 50 Hz
	■ 12.3 m ³ /h at 60 Hz
	■ 15 m ³ /h at 50 Hz
	■ 18.5 m ³ /h at 60 Hz

Oil-free vacuum compressor (SF ₆ gas)	
Final vacuum	Gas flow rate
< 5 mbar abs.	■ 4.8 m ³ /h at 50 Hz
	■ 5.8 m ³ /h at 60 Hz
< 1 mbar abs.	10 m ³ /h at 50/60 Hz
	■ 15 m ³ /h at 50 Hz
	■ 18 m ³ /h at 60 Hz
	■ 35 m ³ /h at 50 Hz
	■ 42 m ³ /h at 60 Hz

Vacuum pump (air) 1)	
Final vacuum	Gas flow rate
< 0.1 mbar abs.	■ 25 m ³ /h at 50 Hz
	■ 30 m ³ /h at 60 Hz
	■ 40 m ³ /h at 50 Hz
	■ 48 m ³ /h at 60 Hz
	■ 63 m ³ /h at 50 Hz
	■ 76 m ³ /h at 60 Hz
	■ 100 m ³ /h at 50 Hz
	■ 120 m ³ /h at 60 Hz

1) Oil-free on request

Approvals

Logo	Description	Country
	EU declaration of conformity	European Union
	EMC directive, EN 61326 emission (group 1, class B) and immunity (industrial application)	
	Machinery directive	
	RoHS directive	

→ For approvals and certificates, see website

Manufacturer's declaration

Logo	Description
	SIL 2 Functional safety

Dimensions in mm [in]

Version without tank

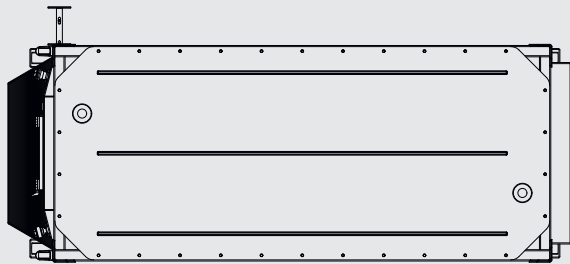
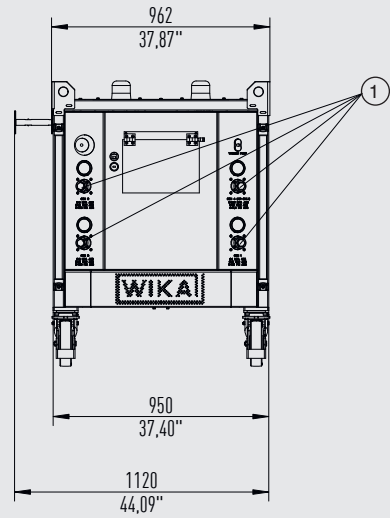
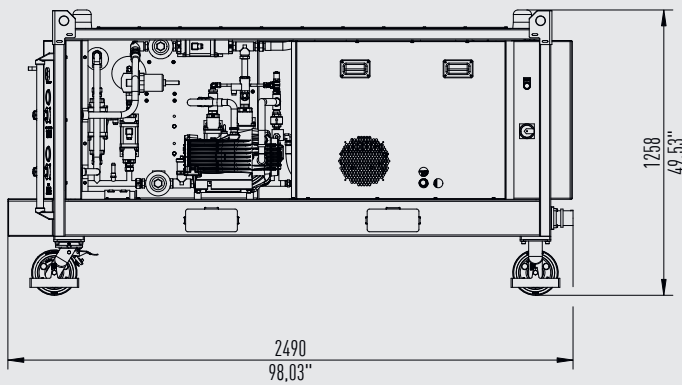

① Connection DN 20

Tare weight: approx. 800 kg [1,764 lb]

14658361.00

Version without Tank and wheels

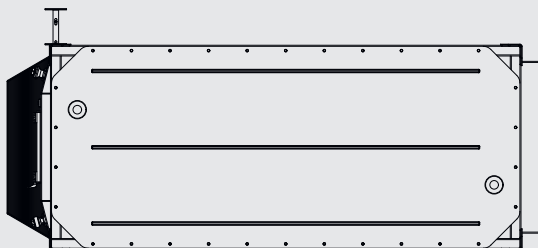
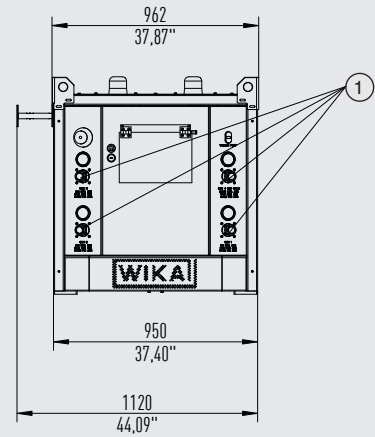
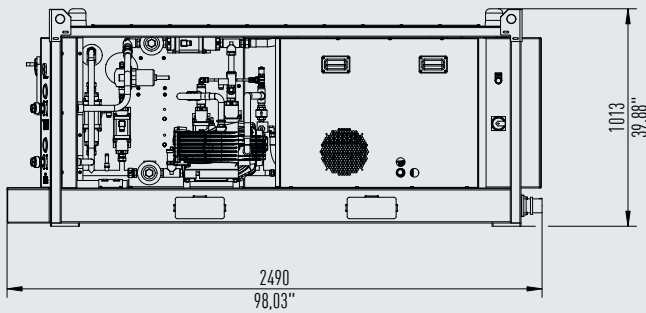

① Connection DN 20

Tare weight: approx. 800 kg [1,764 lb]

14658536.00

Version with 300 litre tank

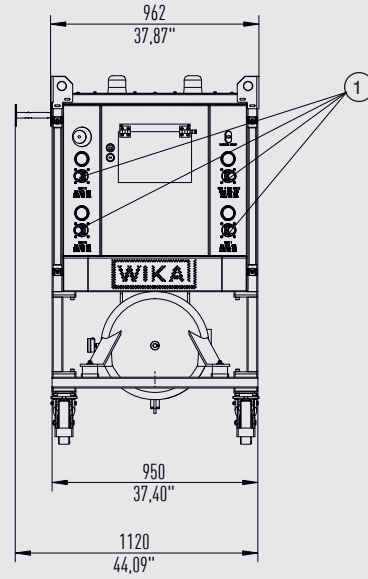
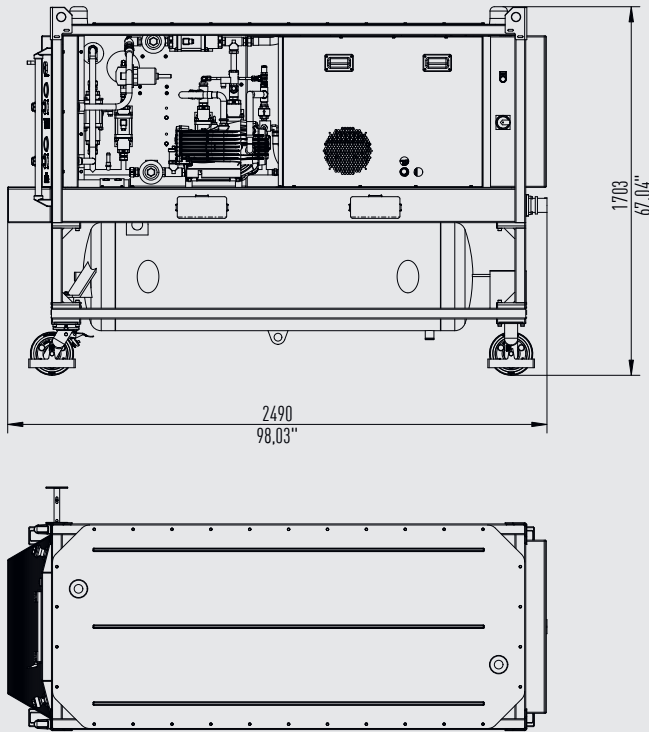

① Connection DN 20

Tare weight: approx. 1,250 kg [2,756 lb]

14658250.00

Version with 600 litre tank

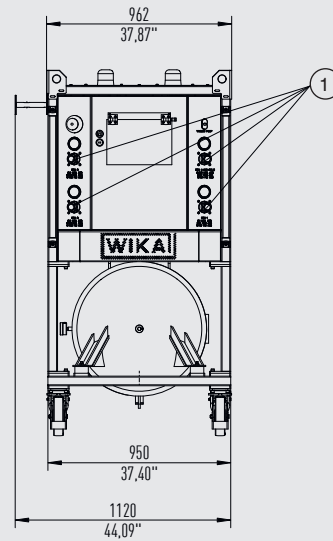
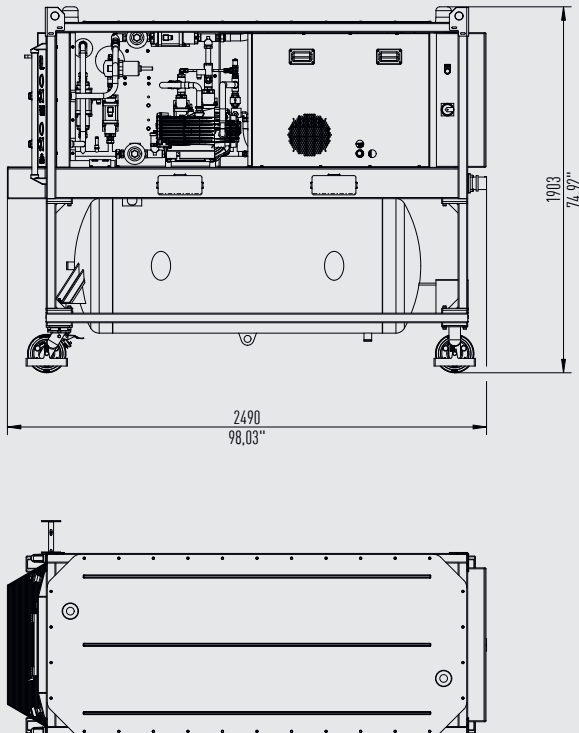

① Connection DN 20

Tare weight: approx. 1,300 kg [2,867 lb]

14658331.00

Version with storage for 6 gas cylinders

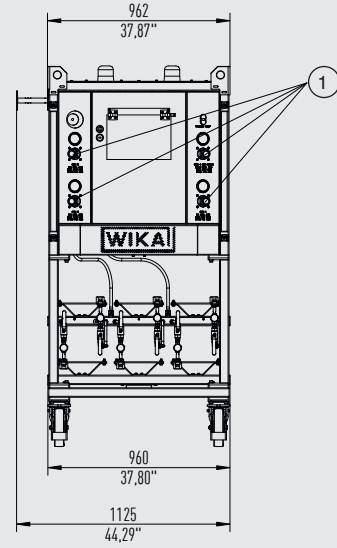
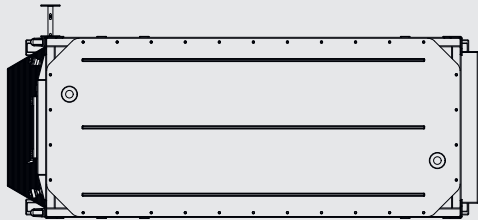
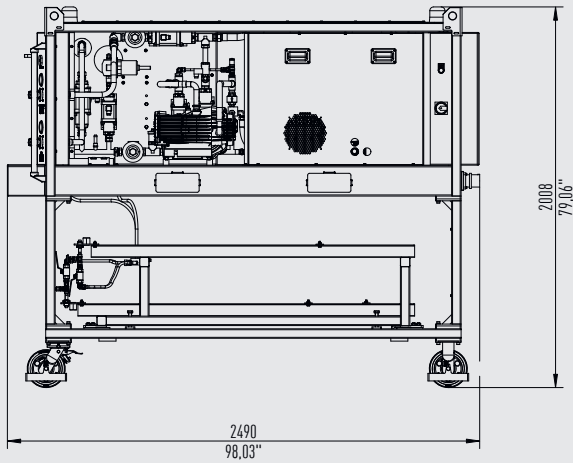

① Connection DN 20

Tare weight: approx. 1,050 kg [2,315 lb]

14658503.00

Version with storage for 10 gas cylinders

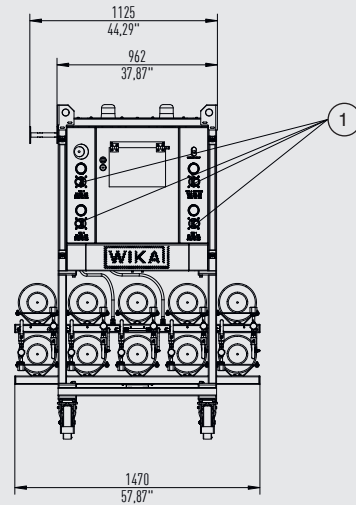
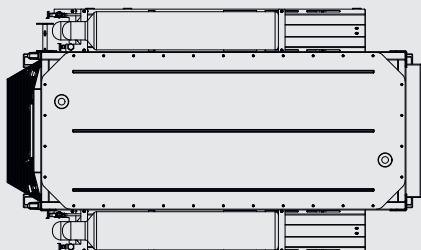
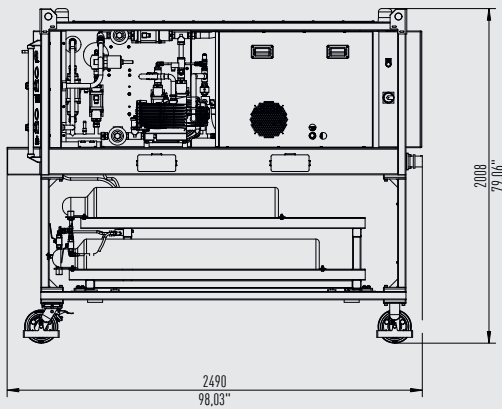

① Connection DN 20

Tare weight: approx. 1,175 kg [2,591 lb]

14658527.00

Accessories and spare parts

Hoses		Order number	
Nominal width	Length	Stainless steel	Rubber
DN 8	3 m [9.84 ft]	14294449	On request
	5 m [16.40 ft]	14330878	On request
	10 m [32.81 ft]	14335098	On request
	15 m [49.20 ft]	14307929	On request
DN 20	3 m [9.84 ft]	14290070	On request
	5 m [16.40 ft]	14307900	On request
	10 m [32.81 ft]	14327574	On request
	15 m [49.20 ft]	14307926	On request

Adapter	Order number
DN 8 (male) to DN 20 (female), brass	14096583
DN 8 (female) to DN 20 (male), brass	14284870

Spare parts and service kits	Order number
Oil for vacuum pump, 1 litre	On request
GPU-x-x000 filter set	14418175
Service kit for compressor (SF ₆ gas)	On request (serial number of the equipment is required)
Service kit for vacuum compressor (SF ₆ gas)	On request (serial number of the equipment is required)
Service kit for vacuum pump (air)	On request (serial number of the equipment is required)
Tarpaulin GPU-x-x000	14182499 (only for version with 300-litre tank)
Pavilion with side pieces for outdoor use	14182512
Trailer	On request

Ordering information

Model / Oil-free vacuum compressor (SF₆ gas) / Vacuum pump (air) / Integrated tank, storage capacity / Accessories

© 05/2018 WIKA Alexander Wiegand SE & Co. KG, all rights reserved.
 The specifications given in this document represent the state of engineering at the time of publishing.
 We reserve the right to make modifications to the specifications and materials.
 In case of a different interpretation of the translated and the English data sheet, the English wording shall prevail.

